

SV-8

Universal Process Indicator User Manual



ABUS TECHNOLOGIES INC.

WARNING

- ❖ This manual should be passed on to the end user.
- ❖ The contents of this manual are subject to change without prior notice.
- ❖ All rights reserved.
- ❖ ABUS gives no warranty of any kind with regard to this manual, including, but not limited to, fitness for a particular purpose.
- ❖ If any question arises or errors are found, or if any information is missing from this manual, please inform your supplier or inform at info@abustek.com.
- ❖ The specifications mentioned in this manual are limited to those for the standard type under the specified model number break-down and do not necessarily apply for customized instruments.
- ❖ Please note that changes in the specifications, construction, or component parts of the instrument may not immediately be reflected in this manual at the time of change.
- ❖ If the customer or any third party is harmed by the use of this product, ABUS assumes no responsibility for any such harm owing to any defects in the product which were not predictable, or for any indirect damages.

Although Warning hazards are related to personal injury, and Caution hazards are associated with equipment or property damage, it must be understood that operation of damaged equipment could, under certain operational conditions, result in degraded process system performance leading to personal injury or death. Therefore, comply fully with all Warning and Caution notices.

Information in this manual is intended only to assist our customers in the efficient operation of our equipment. Use of this manual for any other purpose is specifically prohibited and its contents are not to be reproduced in full or part without prior approval of Technical Communications Department, ABUS Technologies

HEALTH AND SAFETY

To ensure that our products are safe and without risk to health, the following points must be noted:

1. The relevant sections of these instructions must be read carefully before proceeding.
2. Warning labels on containers and packages must be observed.
3. Installation, operation, maintenance and servicing must only be carried out by suitably trained personnel and in accordance with the information given. Any deviation from these instructions will transfer the complete liability to the user.
4. Normal safety precautions must be taken to avoid the possibility of an accident occurring when operating in conditions of high pressure and/or temperature.
5. Chemicals must be stored away from heat, protected from temperature extremes and powders kept dry. Normal safe handling procedures must be used.
6. When disposing of chemicals ensure that no two chemicals are mixed.

Safety advice concerning the use of the equipment described in this manual or any relevant hazard data sheets (where applicable) may be obtained from the Company address on the back cover, together with servicing and spares information.

CATALOGUE

Contents	Page No.
1. Introduction	4
Applications	4
2. Presentation	4
Features	4
3. Dimensions	4
4. Ordering Details	5
5. Connections	5
6. Installation	6
1. Input Signal	6
2. Panel	6
7. Configuration	7
1. Configuration Process	7
2. Key Operation Instructions	8
8. Operation	9
Example for Usage	9
9. Maintenance	9
Troubleshooting	9
10. Safety Precautions	10
11. Warranty	10

1. INTRODUCTION

The SV-8 series of Universal Process Indicators are high performance instruments used for monitoring analog signals in the vast majority of industrial and laboratory processes. Configuration from the front panel can be easily made to accept RT (Ω), mA, voltage or mV signals.

The retransmission of input in form of standard current or voltage signal make it even more adaptive to the process environment, the retransmitted output signal could be further taken to PLCs or other Analog signal processing devices such as Recorders. Two bright 4 Digit displays are Extra Alarm and RS485 MODBUS Communication are available as option.

Applications

The product can support a wide application range to accept and display analog inputs. In process control industry the product finds use to display process parameters from various sensors such as Pressure, Flow, Level, Temperature etc...

2. PRESENTATION

Features

1. Input signals mA, V, mV and RT (Ω) programmable from the front panel.
2. 2 relay alarm output free setting capacity AC 250V/3A or DC 30V/3A.
3. 4~20 mA DC Retransmission output.
4. Auxiliary output power supply 24V/12V DC max 30mA.
5. With RS-485 communication.
6. Accuracy: 0.2% FS.
7. Power supply: 85~260V AC/DC, consumption less than 5VA.

3. DIMENSIONS

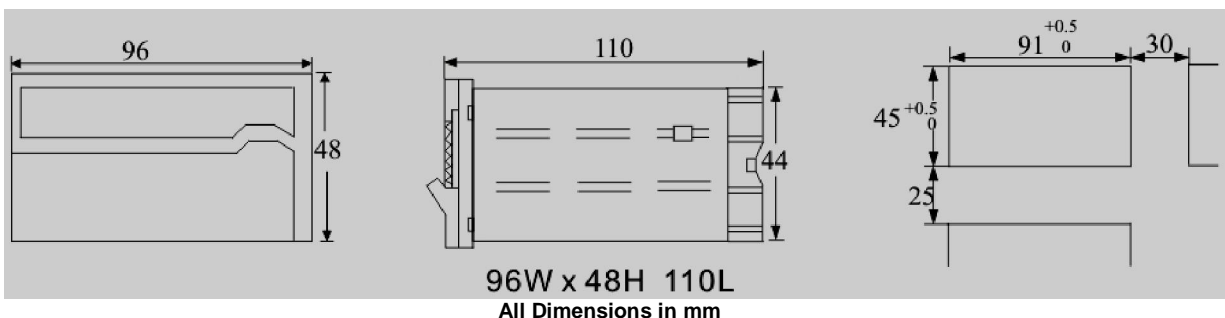

4. ORDERING DETAILS

TYPE				DESCRIPTION
Product	S			Process Indicator
	V			85~265 V AC, 50 Hz
Size		8		48 x 96 x 112 mm
Output		R		Relay Output
		D		4~20mA DC Output
Alarm		B		1 Alarm
		C		2 Alarm
Communication			10	None
			18	RS-485

Example: SV > 8 > D > C > 10

5. CONNECTIONS

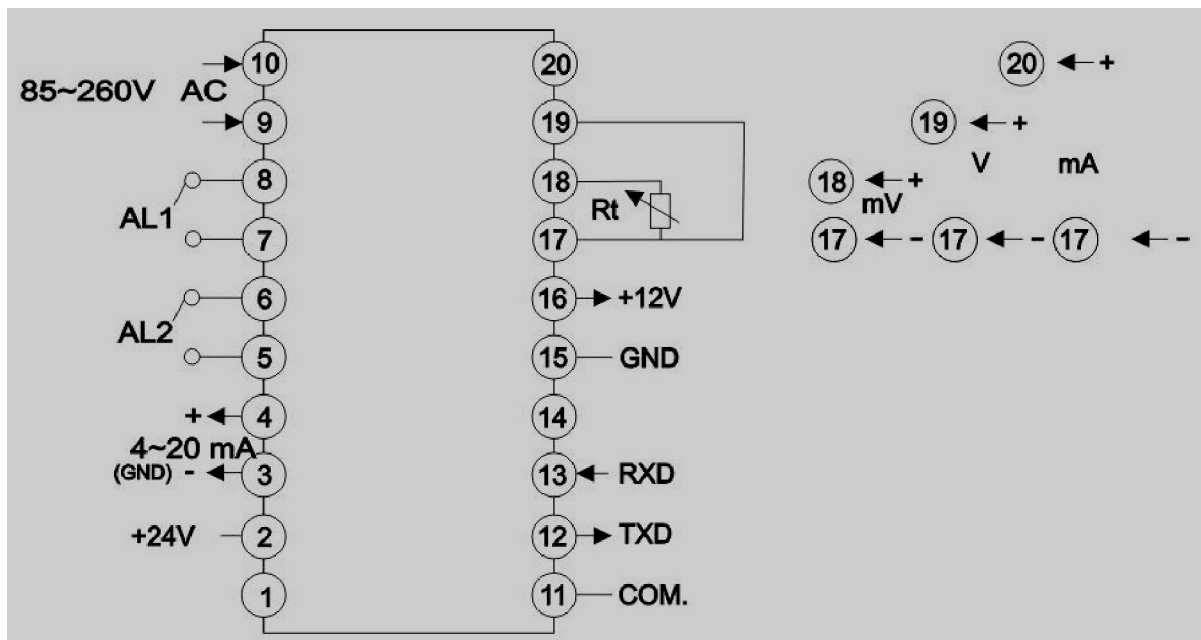

6. INSTALLATION

6.1 Input Signal

INPUT SIGNAL	MEASURING RANGE	INPUT IMPEDANCE	DEFAULT SETTING
mA	0~1 mA 0~20 mA	$\leq 150 \Omega$	4~20mA
V	$\pm 10V$	$\leq 200 K \Omega$	0~5V
mV	-20~100mV	$\leq 2 M \Omega$	0~50mV
Pt (Resistance)	0~400 Ω 0~1K 0~10K	$\leq 0.2 \text{ mA}$ $\leq 0.1 \text{ mA}$ $\leq 0.1 \text{ mA}$	0~400 Ω

6.2 Panel

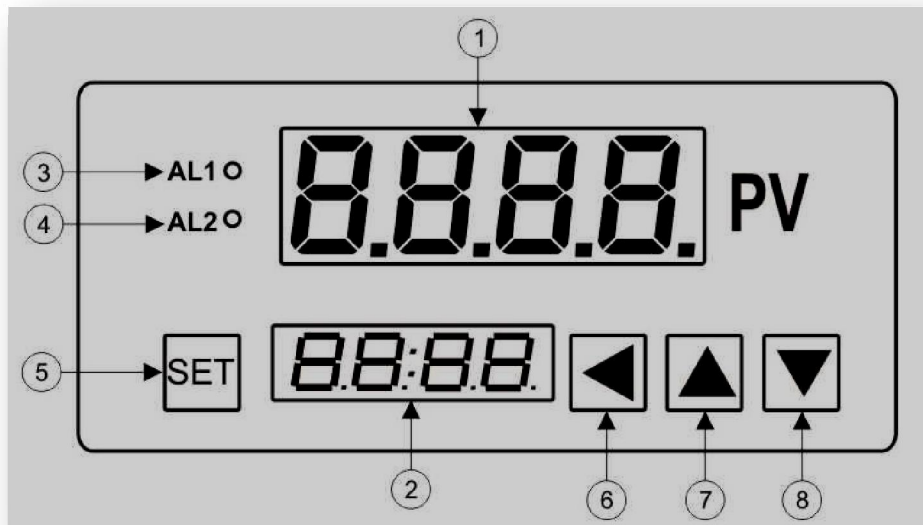

S.NO.	PARAMETERS	DESCRIPTION
1	LED	Up: Measuring value/ Parameter code display.
2	LED	Down: Parameter value/ Input code display.
3	AL1	Alarm1 Indicator lamp.
4	AL2	Alarm 2 Indicator lamp.
5	SET	Parameter select/SET key.
6	◀	Shift Key
7	▼	Decrease Key
8	▲	Increase Key

7. CONFIGURATION

7.1 Configuration Process

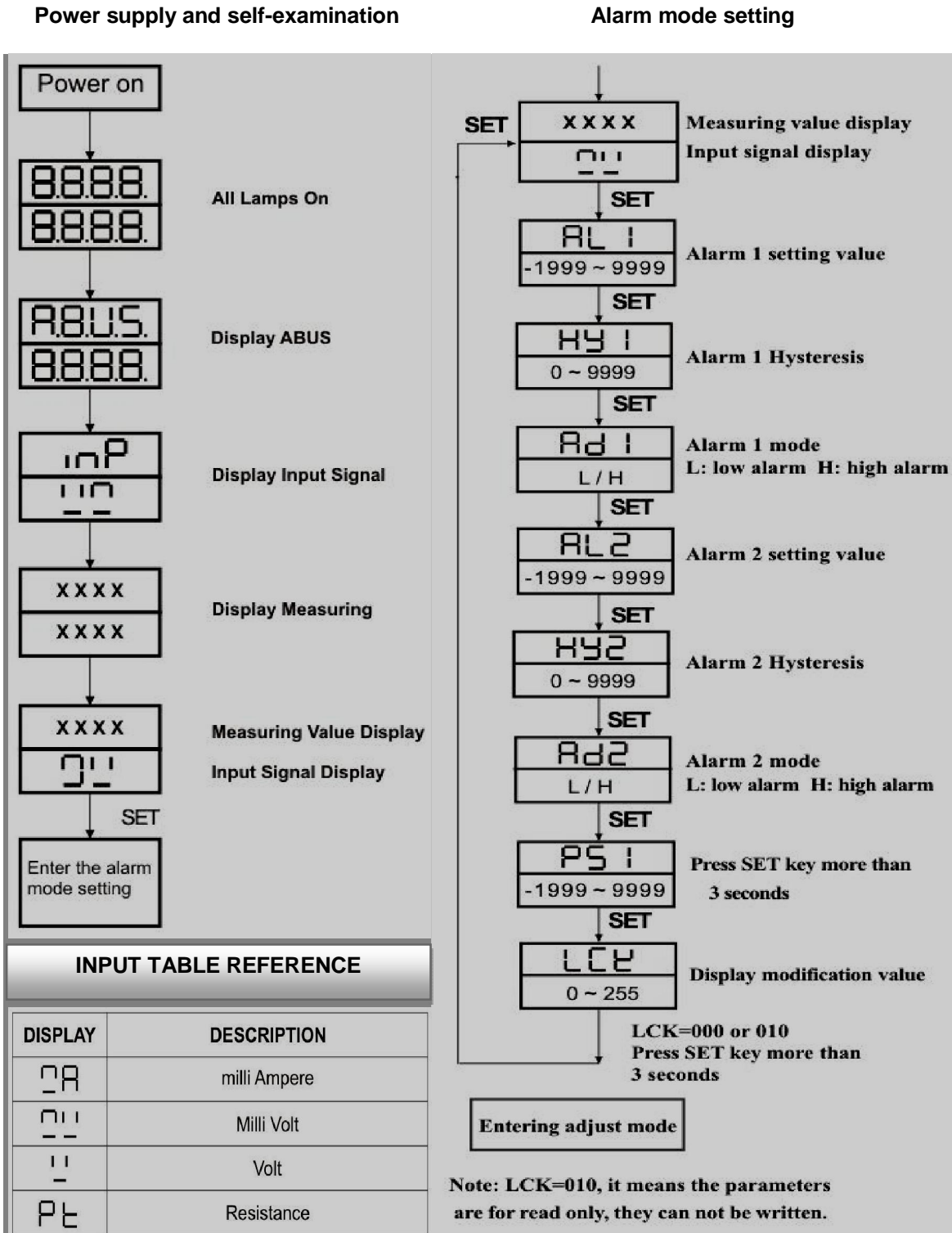

Adjust Setting Mode

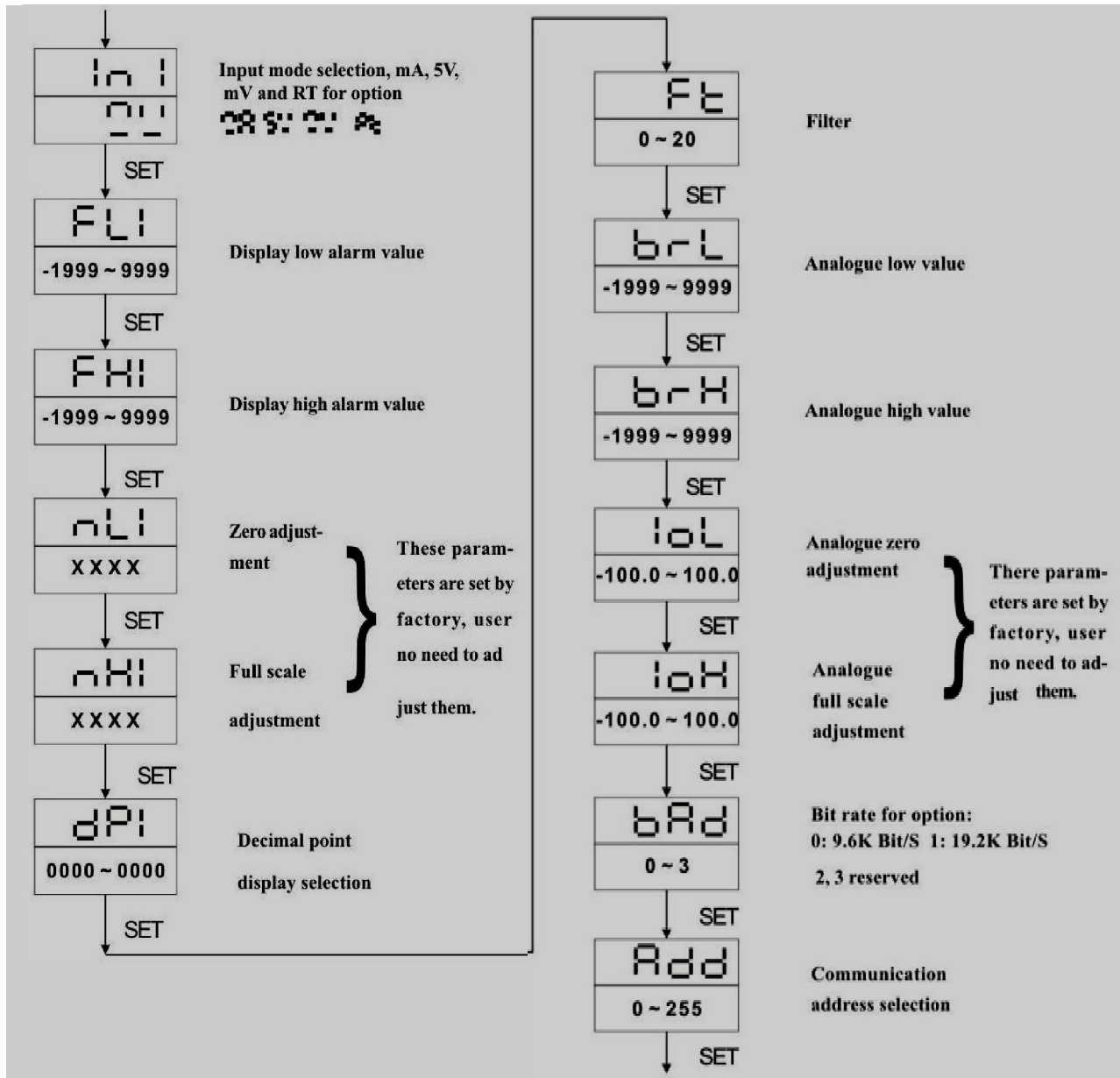

7.2 Key Operation Instructions

1. Press SET key selecting the alarm mode or setting menu. Press ◀ key to shift to the digit that to be modified. LED flashes, press ▼▲ key to modify, then press SET key to confirm.
2. In the menu of the alarm mode, press SET key to select LCK, when the value is 000 or 010, press SET key for 3 seconds, entering the adjust menu. (The operation of other parameters is the same.)
3. The unit will return to measuring estate without key operation for 25 seconds.

8. OPERATION

Example for usage

- Used with 2 wire transmitter. The instrument can supply DC 24V auxiliary power and isolate analogue output 4~20mA. Select input signal mA.

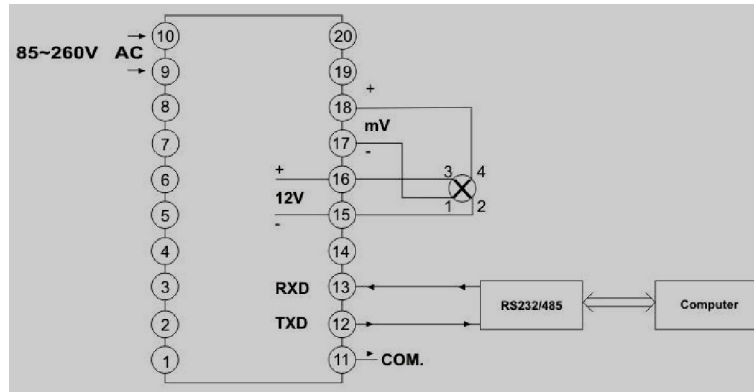

- Used with pressure sensor. The instrument can supply DC 12V auxiliary power, and the sensor output is 2mV/V. Select input signal mV.

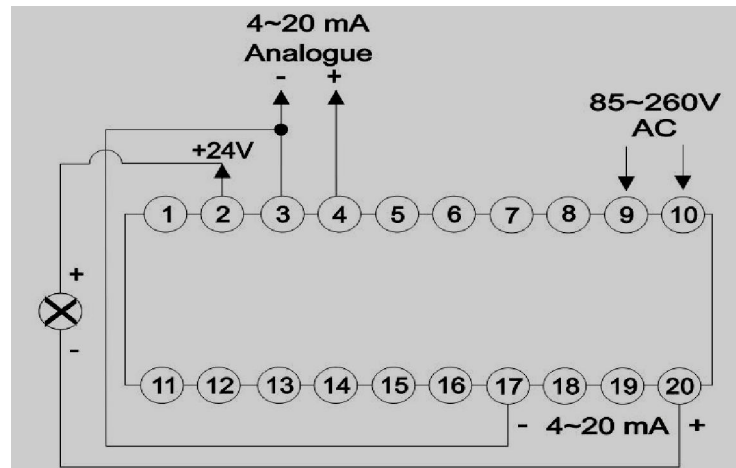

9. MAINTENANCE

Troubleshooting

INFORMATION	SPECIFICATIONS	ELIMINATE
	Sensor not connected or input signal is too low.	Check and connect the sensor properly, or reset the low alarm value. Check the parameters FL1 and FH1.
	Sensor not connected or input signal is too high.	Check and connect the sensor properly, or reset the high alarm value. Check the parameters FL1 and FH1.

10. SAFETY PRECAUTIONS

1. The unit should be powered for 15 minutes before use.
2. Use in ambient temperature of 0-60°C.
3. Avoid vibrations, shock, excessive dust, corrosive chemical materials or gaseous environment.
4. Input wire should not be too long. If measured signal have to be far away from the unit, please use 2-core shielded cable.
5. Use this instrument in the scope of its specifications, otherwise fire or malfunctions may result.
6. Contact of the instrument, with organic solvents or oils should be avoided.
7. Do not turn on the power supply until all of the wiring is completed. Otherwise electrical shock, fire or malfunction may result.
8. Do not disassemble, repair or modify the instrument.
9. All connections should be tightened properly.
10. Power supply should be constant, should not be fluctuating.

11. WARRANTY

ABUS provides the original purchaser of this instrument a one (1) year warranty against defects in material and workmanship under the following terms:

- The one year warranty begins on the day of shipment as stated on the sales bill.
- During the warranty period all costs of material and labor will be free of charge provided that the instrument does not show any evidence of misuse.
- For maintenance, return the instrument with a copy of the sales bill to our factory.
- All transportation and insurance costs should be covered by the owner of the equipment.
- Should any sign of electrical or mechanical shock, abuse, bad handling or misuse be evident the warranty voids and maintenance costs will be charged.

ABUS TECHNOLOGIES INC.

www.abustek.com, E-Mail: info@abustek.com